

LOAD CELL MODEL RLC

SCOPE

The RLC is a low profile, high performance stainless steel ring torsion load cell, suitable for a wide range of applications. With the RLC product family, Revere Transducers introduces a new measuring principle into the weighing market. Due to its compression loading mode the load cell does not suffer from the momentum typically associated with beams, which also require disproportionally large bolts. The RLC type load cell is therefore an inherently safer device, whilst maintaining a profile similar to beams. These instructions are meant to provide the user with a reference of how to use this load cell type in the practical field of weighing applications. **We strongly recommend that this paper is read carefully in order to obtain the maximum benefits of this product line.**

SPECIFICATIONS

Standard Capacities (= E _{max})	t	0.5, 1, 2, 3.5, 5			0.5(75%), 1, 2, 3.5, 5	
Accuracy Class According to OIML R-60		C2	C3	C4	C5	C6
Max. Number of Verification Intervals (n _v)		2000	3000	4000	5000	6000
Minimum Verification Interval (v _{min})		E _{max} /4667	E _{max} /7000	E _{max} /9333	E _{max} /116670	E _{max} /14000
Minimum Utilisation	%	43	43	43	43	43
Minimum Verification interval type MR		E _{max} /9333	E _{max} /14000	E _{max} /17500	E _{max} /23333	E _{max} /28000
Minimum Utilisation type MR	%	21	21	23	21	21
Combined Error	%S	#" 0.0230	#" 0.0230	#" 0.0173	#" 0.0140	#" 0.0115
Hysteresis	%S	#" 0.0250	#" 0.0167	#" 0.0125	#" 0.0100	#" 0.0083
Minimum Dead Load Output Return ¹	%S	#" 0.0250	#" 0.0167	#" 0.0125	#" 0.0100	#" 0.0083
Creep Error (30 Minutes) ¹	%S	#" 0.0245	#" 0.0245	#" 0.0184	#" 0.0147	#" 0.0123
Creep Error (20-30 Minutes) ¹	%S	#" 0.0053	#" 0.0053	#" 0.0039	#" 0.0032	#" 0.0026
Temp. Effect on Min. Dead Load Output	%S/5EC	#" 0.0150	#" 0.0100	#" 0.0075	#" 0.0060	#" 0.0050
T. Effect on Min. Dead Load Output MR	%S/5EC	#" 0.0075	#" 0.0050	#" 0.0040	#" 0.0030	#" 0.0025
Temperature effect on Sensitivity	%S/5EC	#" 0.0050	#" 0.0050	#" 0.0040	#" 0.0030	#" 0.0025
Minimum Deadload	%E _{max}	0				
Maximum Safe Overload	%E _{max}	150				
Maximum Safe Sideload	%E _{max}	100				
Deflection at E _{max}	mm	0.10 " 0.02				
Excitation Voltage	V	5...15				
Maximum Excitation Voltage	V	30				
Rated Output (=S)	mV/V	2 " 0.1				
Output Accuracy for multiple Ic systems	%	" 0.02				
Zero Balance	%S	#" 1.0				
Input Resistance	Û	1115 " 50				
Output Resistance	Û	1025 " 25				
Insulation Resistance	MÛ	\$ 5000				
Compensated Temperature Range	EC	-10...+40				
Operating Temperature Range	EC	-30...+70				
Storage Temperature	EC	-50...+80				
Element Material (DIN)		Stainless Steel 1.4542				
Sealing (DIN 40.050)		IP66/IP68				
Recommended Torque on Fixation Bolts	Nm	12...14				
EEx(I) Certification		EEx ib IIC T6				

1) Applies for the temperature range -10 6 40 EC

Accuracy classes C2 6 C6 are in conformity with OIML recommendation R-60 and certified by the PTB under certificate number 1.13-92.578. Special MR-versions are available for multiple-range scales or applications with a large deadload.

CONSTRUCTION AND DIMENSIONS

The RLC is a fully stainless steel, hermetically sealed load cell. A protection level of IP66/IP68 to IEC 529 is established by the use of laserwelded top and bottom diaphragms and a glass to metal cable entry. Each load cell, is in the final production stage, filled with helium, to verify the sealing. After leak detection the helium is replaced by argon to avoid any residual contamination in the load cell. All compensating components are placed on a printed circuitboard, to provide an optimum resistivity against vibration and shocks by limiting the internal wiring.

A	Fixation hole (3x)
B	Center of load introduction
C	Printed circuit board
D	Circular strain gage (2x)
E	Sealing screw
F	Load cell element
G	Glass to metal cable entry

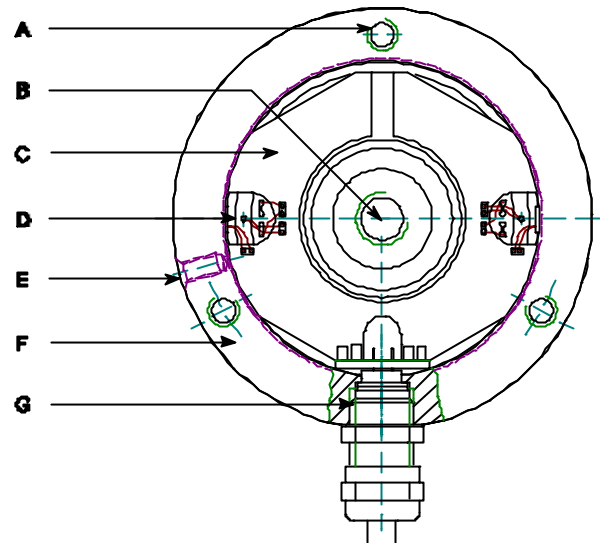

DIMENSIONS: (mm)

The dimension tolerances are according to DIN 7168; middle accuracy, unless otherwise specified.

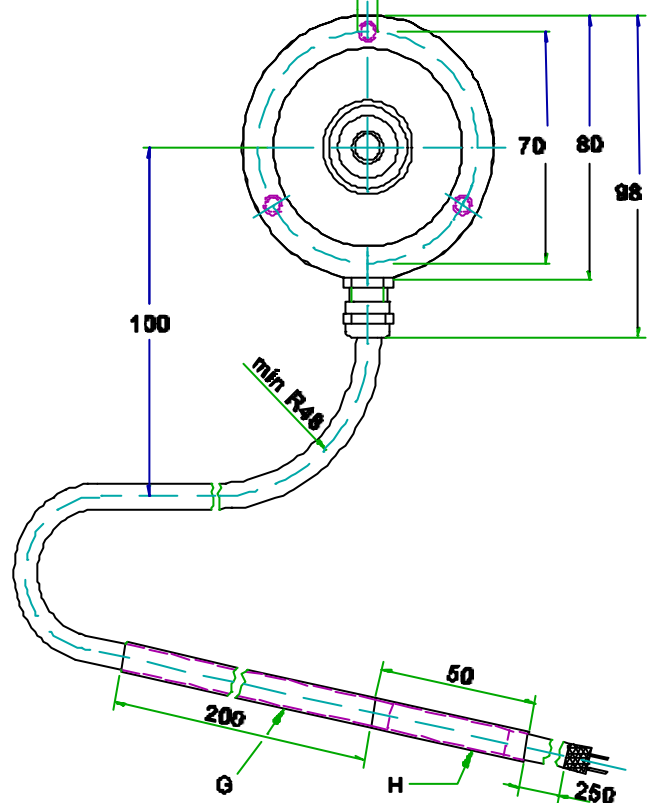
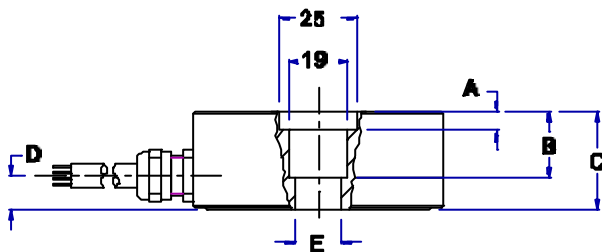

Capacity	0.5, 1	2, 3.5, 5
A	1.0	6.0
B	15.0	20.0
C	25.0	30.0
D	9.5	8.5
E	M10	15 H7
F	M6 (3x120E) 8 Deep	
G	Blue EEx(i)	
H	Label	

⚠ Don't carry load cells by their cables.

⚠ Preserve the minimum radius of 48mm at the cable entry.

MEASURING PRINCIPLE

The measuring principle is based on a full bridge circuit of four circular strain gauges. The strain gauges are bonded to a ring-shaped element which is loaded in compression mode. The element is machined from one piece of stainless steel and has effectively three rings, connected together at precisely defined locations.

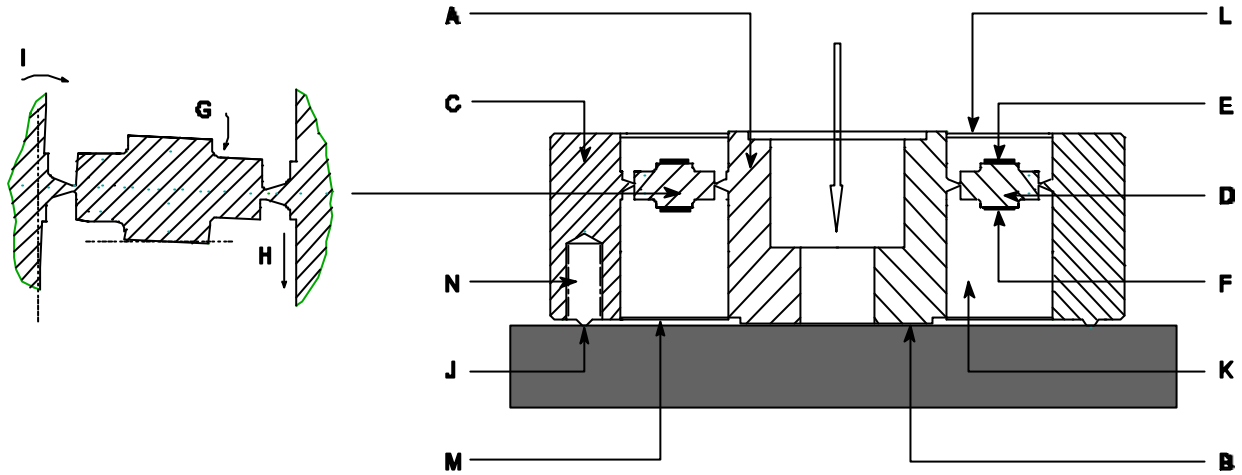

The load is introduced at the inner ring "A" and causes a minimal vertical deflection, directly proportional to this load. Mechanical overload protection is established by limiting the deflection to distance "B" between the inner-ring and the base plate.

The outer ring "C" is supported by the base plate and is connected to the inner ring by a centre ring "D" where the strain gauges "E" and "F" in pairs are located. The center ring will bend "G" when a force "H" is applied. This process will cause a decrease of the diameter at gauge location "E" and an increase of the diameter at gauge location "F". Hence, two gauges are compressed and two gauges are stretched. When the load cell is loaded, the outer ring will bend in the direction "I". This movement is accommodated by the support ridge "J".

The chamber "K" between the inner and outer ring is closed by a top diaphragm "L" and a bottom diaphragm "M". After leak detection, the chamber will be filled with argon to prevent contamination of the critical areas. The load cell can be held captive by using the fixation holes "N" or by three fixation pins surrounding the load cell.

⚠ The surface conditions of the base or mounting plate are critical to obtain the specified accuracy level. We recommend stainless steel plates (for example AISI 304 / DIN 1.4301) with a surface roughness of 1.6.

⚠ It is essential to the performance of the load cell that the outer ring is able to bend when load is introduced. If the load cell is mounted as indicated in the drawing above, we recommend the use of three fixation pins surrounding the load cell, rather than using the fixation holes of the load cell itself. When the load cell is mounted upside down, for example with a platformfoot assembly, M6 socket screws **with a spring washer** "A" should be used to hold the load cell. The screws should be fastened by hand, using **a minimum amount of torque**, while an adhesive "B" can be used to block them.

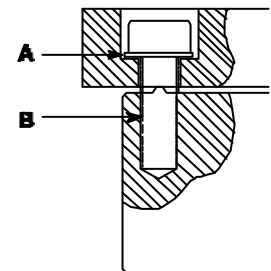

STATIC AND DYNAMIC OVERLOAD

Most load cell failures are related to overloading. The terms related to load/overload are;

Minimum dead load (E_{min}):

The smallest value of a quantity (mass) which may be applied to a load cell without exceeding the maximum permissible error. *Specified as a percentage of E_{max} and equals 0% for the RLC load cell.*

Maximum capacity (E_{max}):

The largest value of a quantity (mass) which may be applied to a load cell without exceeding the maximum permissible error.

Load cell measuring range:

The range of values of the measured quantity (mass) for which the result of measurement should not be affected by an error exceeding the maximum permissible error.

Safe load limit:

The maximum load that can be applied without producing a permanent shift in the performance characteristics beyond those specified. *Specified as a percentage of E_{max} and equals 150% for the RLC load cell.*

Ultimate load limit:

The maximum load that can be applied without physical destruction of the load cell. *Not applicable for the RLC load cell.*

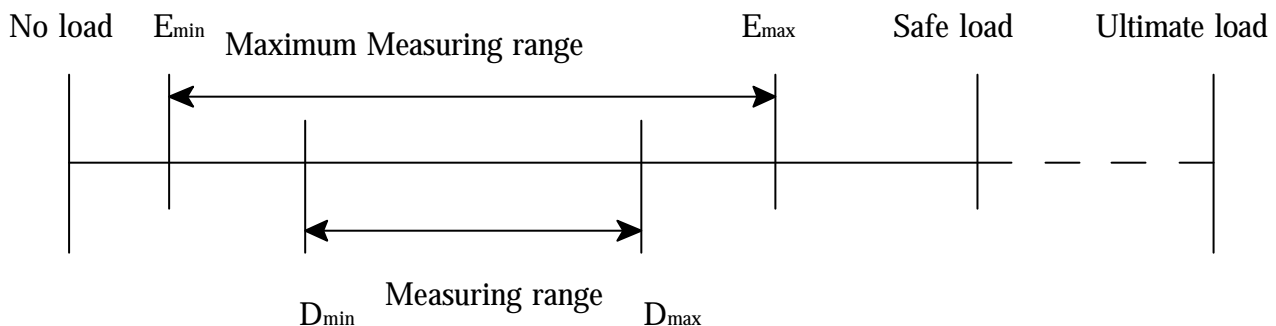

⚠ The RLC load cell is by its design protected against static overload e.g. an increase of load beyond the safe load limited. Any load above approximately 135% of E_{max} will not act on the load cell, but will be transferred directly to the base plate. An ultimate load limit is therefore not specified.

Dynamic overload considers the damage to the load cell which is caused by a relatively small weight with a very short impact time, for example a test weight which is accidentally dropped on the scale from a considerable height. Different types of load cells react differently to dynamic overload. This reaction is related to the load cell deflection. The lower the deflection, the better the dynamic response of the load cell (quick settling time, etc.), but also the more sensitive to dynamic overload.

⚠ The deflection of the RLC type load cell is approximately half that of shearbeams. Particularly for platform scales, where dynamic overload situations can be anticipated, precautions should be taken by choosing the right load cell capacity and incorporating shock insulation paths if necessary.

MOUNTING - INSTALLATION

It is a common misconception that a load cell can be considered as a solid piece of metal on which hoppers or platforms can be supported. The performance of a load cell depends primarily on its ability to deflect repeatably under conditions when load is applied or removed.

- ⚠ The RLC type load cell is not designed to be mounted rigidly between any weighing system and its foundation.
- ⚠ Load cell supports should be designed which avoid lateral forces, bending moments, torsion moments and off centre loading to the load cell.

Revere Transducers offers two mounting systems which are specially designed to meet the above requirements. The RLC self aligning silo mount, combined with the RLC load cell family, provides weighing assemblies suitable for process control, batch weighing, silo/hoppers and belt scale applications.

The fully stainless steel mount incorporates a "rocker pin" design that combines excellent load introduction to the transducer with a low profile. Hardened stainless steel components are used at all

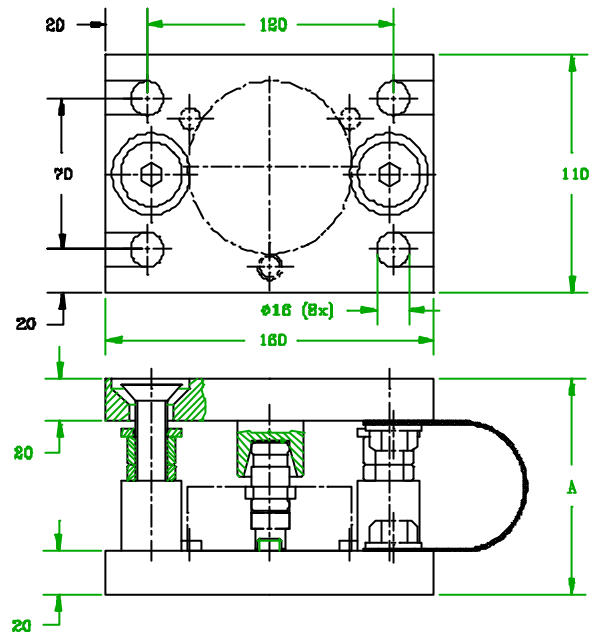
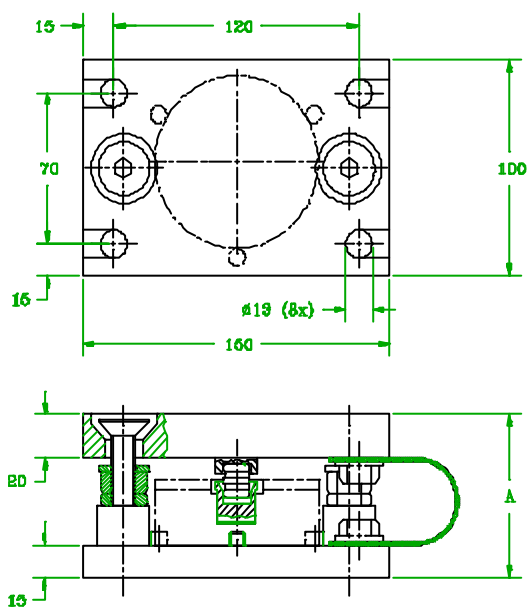

bearing surfaces.

Standard Capacities	t	0.5, 1
"A" at Operation	mm	75
"A" During Installation	mm	80
Max. Vertical Force (Compression)	kN	15
Max. Vertical Force (Tension= lift-off)	kN	10
Max. Horizontal Force (All Directions)	kN	5
Max. Horizontal Movement	mm	3
Mount Material (DIN)		1.4305

Standard Capacities	t	2, 3.5, 5
"A" at Operation	mm	100
"A" During Installation	mm	105
Max. Vertical Force (Compression)	kN	75
Max. Vertical Force (Tension= lift-off)	kN	10
Max. Horizontal Force (All Directions)	kN	10
Max. Horizontal Movement	mm	3
Mount Material (DIN)		1.4305

The RLC mount tolerates controlled movement in all directions. The silo or hopper is held captive, eliminating the need for additional check rods, unless major load movement is anticipated. The unique design allows the load cell to be placed or replaced after installation of the mount.

The RLC self aligning foot assembly, combined with the RLC load cell family, provides weighing assemblies suitable for medium capacity platform scales and belt scale applications. The fully stainless steel assembly combines excellent load introduction to the transducer with a low profile design. Hardened stainless steel components are used at all bearing surfaces.

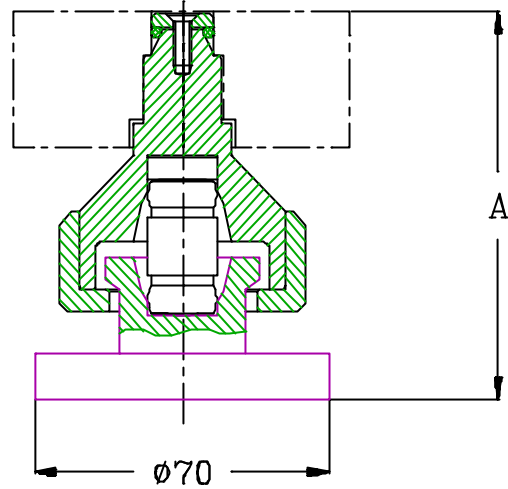
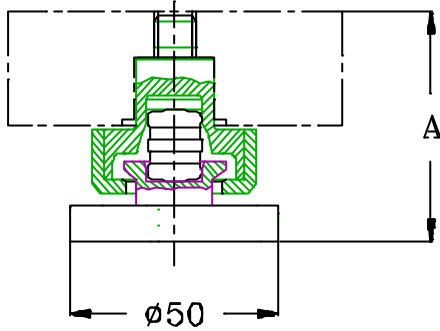



Standard Capacities	t	0.5, 1
Dimension "A"	mm	51
Max. Vertical Force (Compression)	kN	15
Max. Horizontal Movement	mm	2.5
Mount Material (DIN)		1.4305

Standard Capacities	t	2, 3.5, 5
Dimension "A"	mm	86
Max. Vertical Force (Compression)	kN	75
Max. Horizontal Movement	mm	2.5
Mount Material (DIN)		1.4305

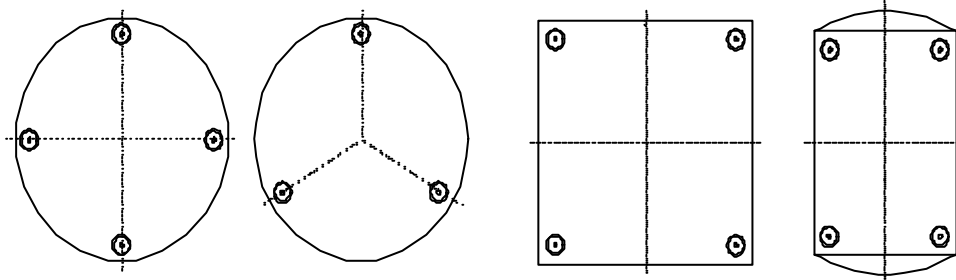
The drawings below represent typical weighing systems. The load cells are arranged in such a way that all load cells share an equal part of the weight, whilst the centre line of the leg/load passes through the centre of the load cell.





 All load cells should be placed on the same horizontal plane and level.

 As with most load cells these mounts are particularly simple and effective. On a first inspection they may seem to be easily manufactured. However, we use specialised types of stainless steel which are not readily available as well as critical hardening techniques in the mounts manufacture. This ensures that the weighing system will have an optimal accuracy as well as long term stability under normal operating conditions. Should the manufacturing techniques and materials not meet the criteria, then performance may be compromised.

ELECTRICAL CONNECTIONS

The RLC type load cell is provided with a four-wire shielded cable. The cable response to temperature changes is eliminated by making the cable part of the temperature compensation system of the load cell.

-  The load cell is calibrated and compensated with the provided cable length. Never cut the load cell cable!
-  The cable shield is galvanically connected with the housing of the load cell to provide adequate protection against electrostatic interference.

Most industrial load cells are used in multiple load cell weighing systems. Usually the inter-connection is not made at the indicator, but in a separate housing, a junction box, located adjacent to the weighing system. The figures below represent the two basic configurations, using a four- or six-wire (with sense) extension cable. Four wire extension cables require the load cell output to be connected to pairs of diagonally opposite wires. We recommend the use of a 6-wire extension cable, specially for approved weighing systems, to avoid any temperature effects on it.

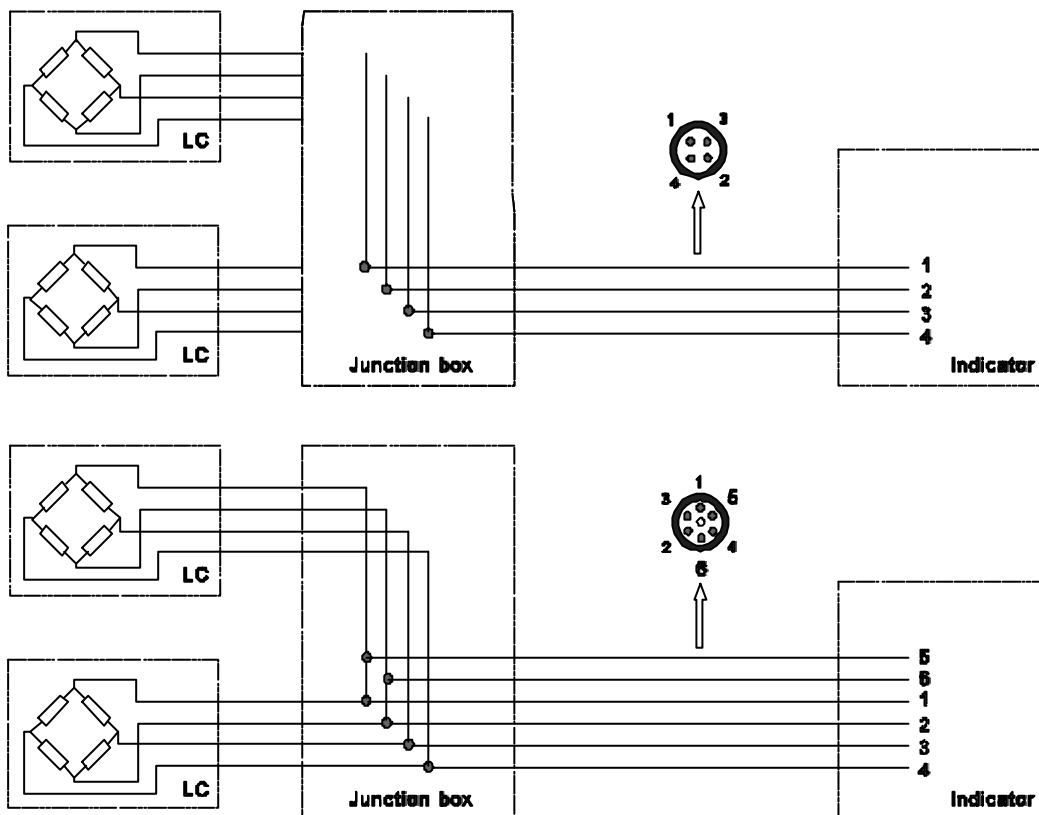

Electrical connections	
1	+ Excitation
2	- Excitation
3	+ Output
4	- Output
5	+ Sense
6	- Sense

RLC wiring code	
+ Excitation	Pink
- Excitation	Grey
+ Output	Brown
- Output	White

The cable connections in the field should be made in a junction box with a protection degree of at least IP65 (DIN.40.050 / IEC 529). The degree of protection can only be achieved if the junction box is installed correctly:

- # Select the right location based on the environmental conditions, NOT on the ease of installation.
- # Put on the cover-screws according to the manufacturer's specifications.
- # Place the cable-entries downwards and provide a dripping-loop in the cable.

Moisture could decrease the insulation resistance of the circuit and might cause unstable readings. A bag with drying agent (silicagel) should be enclosed to absorb condensation. This bag should never make contact with any un-insulated wiring in the junction box.

The figure opposite shows the correct installation, with cable entries placed downwards and dripping loops.

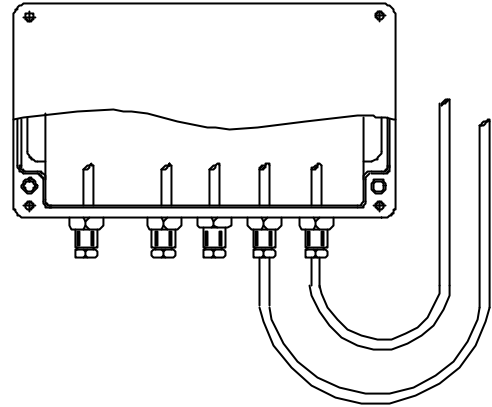

- ⚠ Ensure that no moisture enters the open cable end or cable connections before and during installation.

The RLC type load cell provides a rationalised output, which makes additional balancing resistors for multiple load cell systems unnecessary. The output current of each individual load cell is in the final stage of production matched to a reference cell with a tolerance of "0.02%. This results in a maximum corner difference of 0.04%, approximately 50 times better than conventionally calibrated load cells. The output is rationalised by placing a small resistor in the + output line. As the welding of the diaphragms influences the span output, the resistor is placed at the end of the load cell cable.

- ⚠ We strongly recommend not to remove the balancing resistor at the end of the load cell cable, as the load cell output will not longer be rationalised.
- ⚠ Load cell cables should be kept away from power circuits with a recommended distance of at least one metre. Power supply cables should cross at right angles.
- ⚠ In case of insulation resistance measurements, the test voltage should never be applied between cores of the load cell cable. This will damage the strain gages beyond repair. The maximum permissible test voltage is 50 Vdc.
- ⚠ Avoid electrical welding after installation of the load cells. If welding is necessary and the load cells can not be removed then disconnect each individual load cell cable from the junction box or measuring instrument. Place the earthing electrode of the welding apparatus in close proximity to the weld, to avoid a current path through the load cells. Further, connect a flexible copper lead of at least 16mm² cross-section between the system and foundation over each load cell.

HAZARDOUS AREAS

The technique for preventing explosions by limiting the electrical energy available in circuits is called *Intrinsic safety (EEx(i))*. It is essentially a low-power technique, so exceptionally suitable for load cells. Equipment in the hazardous area must be certified or be non-energy-storing "*simple apparatus*". The temperature classification allocated to simple apparatus is T4 (135E), provided the matched power is less than 1.3W at 40EC, 1.2W at 60EC and 1.0W at 80EC. Simple apparatus require an insulation test with an applied voltage of 500 volts. Revere Transducers has the means to carry out this test correctly, after which a statement will be made that the specific load cell has passed the test successfully.

Although load cells can be considered as being "simple apparatus", a certificate is often requested for enhanced safety or insurance reasons. The RLC type load cell is available with a CENELEC certificate for use in hazardous areas. These load cells are verified and tested in conformance with EC regulations EN 50.014 (general requirements) and EN 50.020 (Intrinsic safety "i") and are marked:

EEx ib IIC T6

The supply circuit and the output circuit are galvanically connected and may only be used in conjunction with certified intrinsically safe circuits (zenerbarriers) within the following tolerances:

ÓU	#	19.1 V
ÓI	#	323 mA
ÓP	#	1.25 W

The internal capacitance equals 0.4 nF, the inductance is negligibly small.

All load cells placed in a hazardous area must be connected to zenerbarriers to limit the energy. Barriers placed in a load cell circuit not only limit the energy that may be transferred to the hazardous area under fault conditions, but also restrict the operating voltage that may be applied to the wheatstone bridge. This is because of the considerable end-to-end resistance of the barriers. The RLC type load cell with an input resistance of over a 1000Ω is excellently suited for barrier-applications.

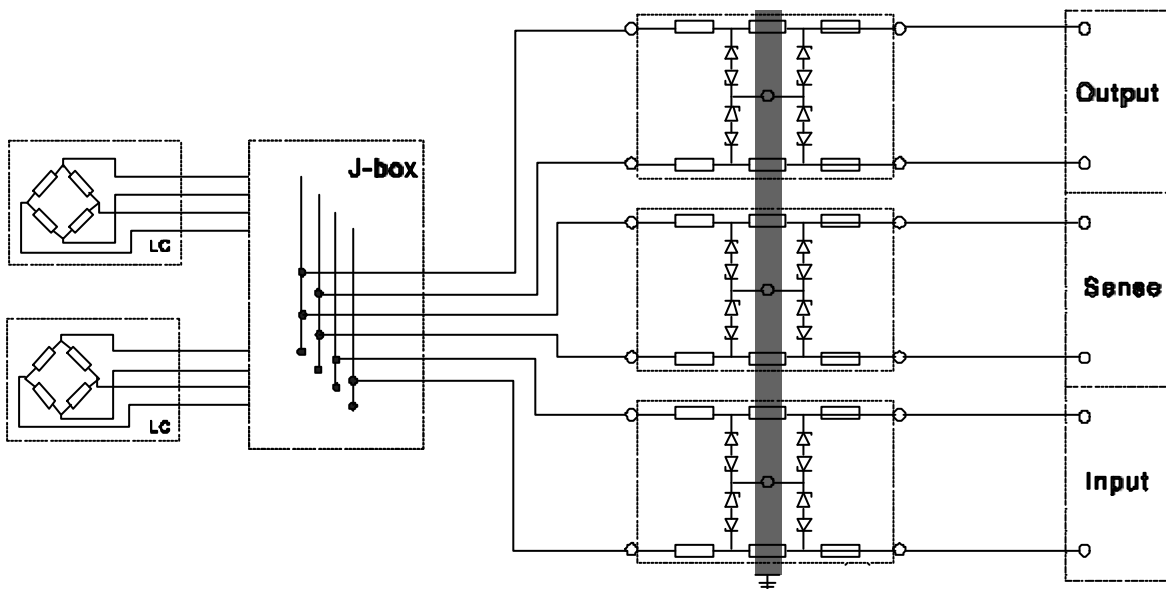

A basic circuit is given in the diagram below:

A dual-channel barrier is used for the excitation (indicator output) and the signal (indicator input) circuit. A third dual-channel barrier is used to actually sense the applied voltage over the load cells.

EN 45501, REQUIREMENTS FOR LOAD CELLS

Section 4.12 of EN 45501 (OIML R76) requires that load cells have been tested in conformity with International Recommendation OIML R60. These load cells can be applied in three groups of weighing instruments:

1) Single interval instruments:

Instrument having one weighing range.

2) Multiple range instruments:

Instrument having two or more weighing ranges with different maximum capacities and different scale intervals for the same load receptor, each range extending from zero to its maximum capacity.

3) Multi-interval instruments:

Instrument having one weighing range which is divided into partial weighing ranges, each with different scale intervals, with the weighing range determined automatically according to the load applied, both on increasing and decreasing loads.

It is beyond the scope of these instructions for use to cover all requirements for the above mentioned groups of weighing instruments. The main requirements for single interval instruments are covered, For more information please refer to RTE Application Note 09/4-10/01 "Legal Metrology".

1 The maximum capacity of the load cell shall satisfy the condition:

$$E_{\max} \geq \frac{Q \cdot \text{Max} \cdot R}{N}$$

Where:

E_{\max} : maximum capacity of the load cell (kg)

N : Number of load cells

Max : Maximum scale capacity (kg)

R : Reduction ratio; load acting on the load cell(s) divided by load acting on the scale

Q : Correction factor

The correction factor $Q > 1$ considers the possible effects of eccentric loading, dead load of the load receptor (scale), initial zero setting range and non uniform distribution of the load.

To be precise; the total capacity of all load cells should be larger or equal to the maximum capacity of the scale, the dead weight of the construction and the overall effect on zero-setting and zero-tracking devices. The overall effect of zero-setting and zero-tracking devices shall be not more than 4% and of the initial zero-setting device not more than 20%, of the maximum capacity. Further to this, the following eccentric loading conditions should be considered:

- On an instrument with a load receptor having n points of support, with $n \geq 4$, the fraction $\frac{1}{(n-1)}$ of the sum of the maximum capacity and the maximum additive tare effect shall be applied to each point of support.
- On an instrument with a load receptor subject to minimal off-centre loading (e.g. tank, hopper) a test load corresponding to one-tenth of the sum of the maximum capacity and the maximum additive tare effect shall be applied to each point of support.

If the above considerations are applied on a platform scale with a capacity of 1500 kg and a dead load of 100kg, the individual load cell capacity if four load cells are used can be calculated by:

Eccentricity behaviour tested with $\frac{1}{(n-1)} \cdot \text{Max} = \frac{1}{3} \cdot 1500 = \mathbf{500kg}$.

Dead load weight distribution equals $100/n = 100/4 = \mathbf{25kg}$.

Zero-setting/tracking: $(24\% \text{ of } 1500)/n = 360/4 = \mathbf{90kg}$.

Hence, the load cell capacity (E_{\max}) should at least be $500 + 25 + 90 = \mathbf{615kg}$.

2 The maximum number of load cell intervals shall satisfy the condition:

$$n_{lc} \geq n$$

For each load cell, the maximum number of load cell intervals n_{lc} shall not be less than the number of verification scale intervals n of the instrument, e.g. a 3000d class II weighing instrument should have at least class C3 load cells.

3 The minimum load cell verification interval shall satisfy the condition:

$$v_{\min} \leq e \cdot \frac{R}{\sqrt{N}}$$

The minimum load cell verification interval v_{\min} shall not be greater than the verification scale interval e multiplied by the reduction ratio R of the load transmitting device and divided by the square root of the number N of load cells. This formula can be rewritten as:

$$e \geq v_{\min} \frac{\sqrt{N}}{R}$$

For example, a platform scale with a capacity of 1500 kg is built with four load cells, type RLC-C3-1t, with $v_{\min} = E_{\max}/7000$.

- 1) The load cell capacity is in agreement with point 1 (see calculation example).
- 2) The maximum number of scale intervals should be smaller or equal to the maximum number of load cell verification intervals. Hence, the maximum number of scale intervals is 3000.
- 3) By applying the formula given at point 1.3, the minimum value for e can be calculated:

$$e \geq v_{\min} \frac{\sqrt{N}}{R} \quad e \geq \frac{1000}{7000} * \frac{2}{1} \quad e \geq 0.286 \quad e = 0.5 \text{ kg}$$

It is important to verify the output per scale division with the required minimum signal level for the measuring device to ensure compatibility. The output per scale division (in μV) can be calculated by:

$$\frac{U_E * S * \text{Max} * 1000}{N * E_{\max} * n}$$

where:

- U_E : Excitation voltage
- S : Rated output load cell
- N : Number of load cells
- n : Number of scale divisions

The RLC load cell has a rated output of 2 mV/V. The output per verification scale interval at an excitation voltage of 10 V for the example above will be:

$$\frac{10 * 2 * 1500 * 1000}{4 * 1000 * 3000} = 2.5 \text{ mV}$$

FURTHER INFORMATION

- ⚠ A warming-up time of at least 10 minutes for the load cell is recommended before calibration of the weighing system.
- ⚠ Pollution on the load cells and on the moveable parts of the weighing installation have to be cleaned in due time, especially if the pollutant is aggressive to the materials used.
If necessary the load cell and mount can be protected by anti-corrosion grease or an off-shore all weather protection spray.

In case of a failure, or wrong measuring results, the following points should be addressed:

- Check whether vertical force shunts (cables, pipes, etc.) are disturbing the required ability of the load cell to deflect.
- Check whether there is any other disturbance such as pollution, thermal expansion, etc.
- Check whether all load cells are positioned horizontally and correctly.
- Check whether moisture has entered the cable junction box, whether the cable connection is proper or whether cables are damaged.
- Check each load cell separately by corner point loading in order to find out which load cell generates the failure. If possible, test this load cell with a DC-meter against its original electrical values, as mentioned on the calibration sheet.

- ⚠ If a load cell fails, and is sent back to Revere Transducers, please provide clear and accurate information relating to the problem or mode of failure.

Customer support:

The Revere Transducers group combines fifty years of load cell manufacturing with fifty years of application know how. For any further information, please contact our manufacturing operation or any one of our regional sales offices. Application notes and accessory information is available on the following subjects:

Application note 09/3-01/01	Wind forces
Application note 03/4-02/01	Load cell cabling
Application note 09/3-03/02	Shunt diode barriers
Application note 10/3-04/01	Hazardous areas
Application note 02/4-06/01	Vessel weighing
Application note 04/4-07/01	Environmental conditions
Application note 06/4-08/01	Current calibration
Application note 08/4-09/01	Lightning protection
Application note 09/4-10/01	Legal Metrology

Revere Transducers Europe

Ramshoorn 7
Postbus 6909, 4802 HX Breda
The Netherlands
Tel. (+ 31)76-5480700
Fax. (+ 31)76-5412854

Regional offices in Germany, France and United Kingdom

